

# Auto Shuttle

---

Self Powered, Deep Lane  
Pallet Storage Solution





High density inside,  
high access outside.

# Auto Shuttle systems.

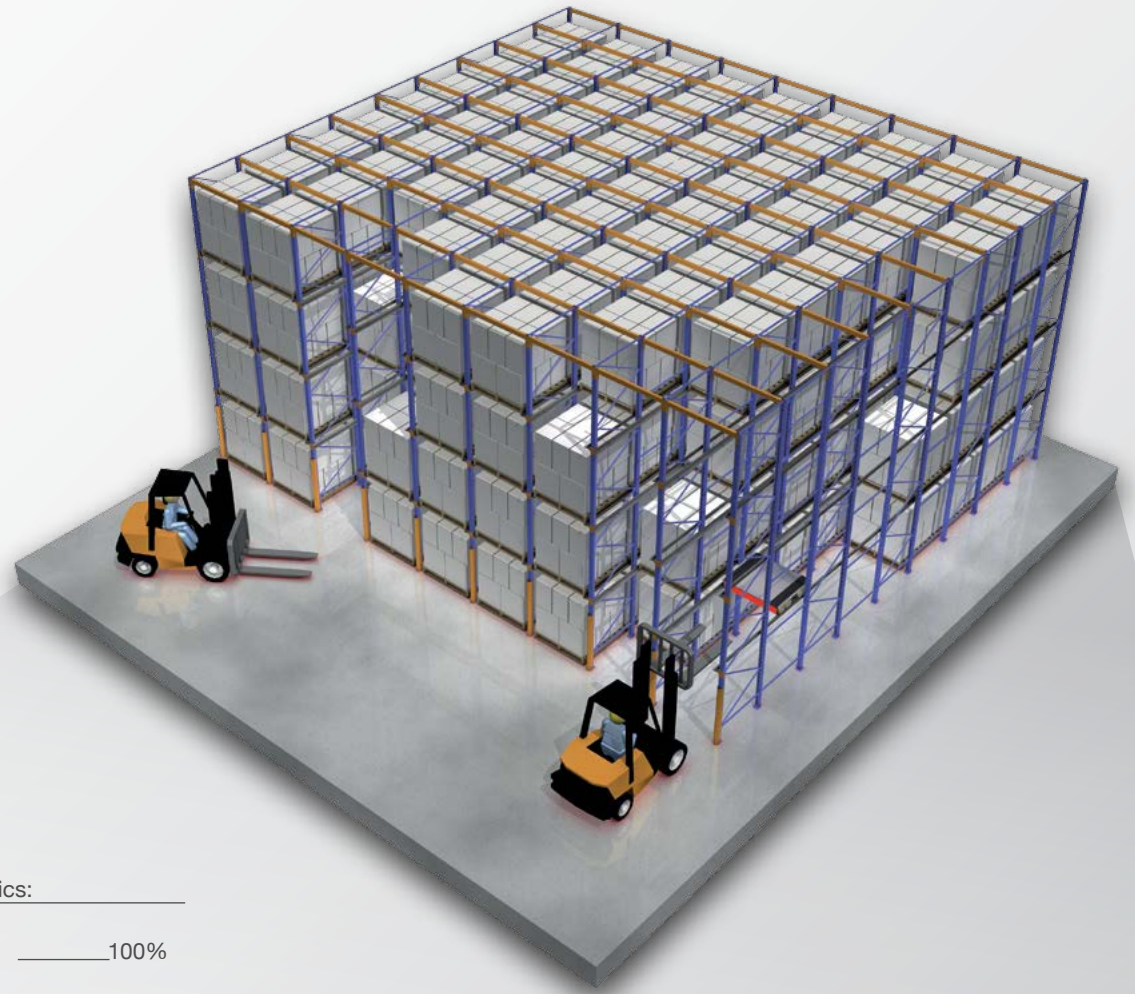

## Your business:

You have a low SKU count and large batches of raw materials or finished goods. Stock can be either highly active or static, but storage density is a major feature you require. You typically dispatch by batch and use either First In First Out or Last In First Out.

## Our solution:

The Dexion Auto Shuttle systems offers high-density pallet storage without the use of forklifts. It makes the most of limited space and forklift truck fleets. The Auto Shuttle unit deposits and retrieves pallets within the system. A Shuttle solution is applicable for 'pack and hold' operations where pre-picking and staging is possible, 'dock split' and 'hold' operations, and the staging of outbound pallets by route or truckloads in lieu of conventional floor staging.

## The vital statistics:

Average locations used \_\_\_\_\_ 100%

Immediate accessibility \_\_\_\_\_ up to 100%

Stock rotation \_\_\_\_\_ Excellent

Average floor area by pallet position (sqm) \_\_\_\_\_ 0.49

# Shuttle stock back and forth.

The Auto Shuttle unit travels below the pallets then elevates the pallet from the support rails and carries it back and forth within the system as required. The Auto Shuttle unit is mechanically propelled ensuring high reliability and low energy consumption.



# Best in breed equipment.

Best in breed equipment, patented mechanical lifting motion, means no hydraulics and few moving parts, ensuring low noise during operations. If an error is detected, the Auto Shuttle unit will return to the home position for easy retrieval and repair.



The Auto Shuttle unit incorporates a range of features, such as collision protection for the front and rear pallets to ensure safe handling and consideration for pallets with overhang. A status indicator on the front face provides vital information to the operator, and a unique lifting function allows pallets to be densely packed along the rail. Distance between pallets is adjustable between 0mm to 200mm. The Auto Shuttle unit also has the ability to count pallets in a lane.



At your fingertips.



# Control via handheld remote.

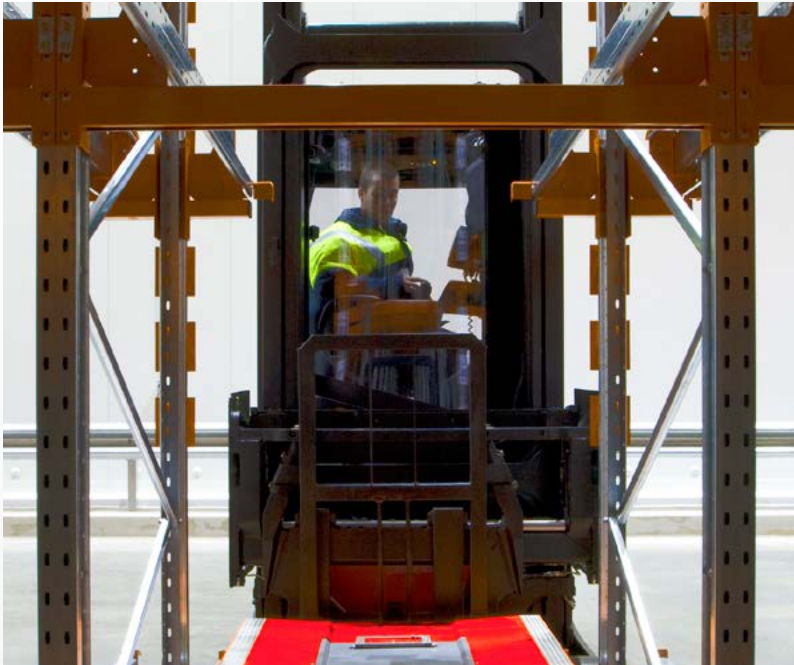

Scanning with RF device, the screen tells the operator the destination of the pallet within the rack. The Auto Shuttle unit is controlled via the hand held remote.





7357

003 003  
A048-04  
6555

7904

Positions pallets perfectly.

Lead in guides act as a visual and physical aid for the forklift operator to assist with the placing of the Auto Shuttle unit and pallets.



# High density with operational safety.

The rails support and guide the Auto Shuttle in operation. The rails provide detection holes which are aligned with the satellite unit sensors for shuttle unit operation. High tolerance rail joints allow for smooth running of the Auto Shuttle unit in deeper storage applications.



The shuttle unit deposits and retrieves pallets within the high density core of the Auto Shuttle system.

A conventional forklift truck places the pallet on the rails ready for the Auto Shuttle to move the pallet into position. Similarly it collects the pallet from the front of the rack once retrieved by the Auto Shuttle. Pallets sit on their own rails, facilitating access of pallets on each level. The forklift does not enter the racking structure. This ensures the safety of the forklift driver, and prevents damage of the rack.



# Auto Shuttle features.

- Auto Shuttle weight 250kg
- 8 wheel maximum load weight 2000kg
- 4 wheel maximum load weight 1500kg
- Typically capable of moving up to 70 pallets/hour
- 8 wheel operating temperature -30°C up to 40°C
- 4 wheel operating temperature 5°C up to 40°C

3 to 4 hour recharge time, automatic battery recharging solution available for 8 wheel shuttle

## OR

A variety of battery change-over options including:

- In-rack battery change over option
- Traditional battery charging rooms
- Battery changeover process
- Lithium battery 8 wheel
- Lead acid battery 4 wheel

Auto Shuttle operation controlled by sensors:

- Side sensors (beginning and end)
- Front sensors (pallet detection)
- Top sensors x 4 (pick up detection)

Eccentric drive lifting process enables unit to lift half of the load at a time to prolong battery life.

Emergency stop safety bar, front and rear.

LED display provides the operator with visual confirmation of the Auto Shuttle status.

Illustrative purposes only.

8 wheel design delivers greater carrying capacity and ensures longer rail life. 4 wheel design also available.

Guide wheels for increased stability.

Brushes are located in front of the guide wheels or along the side of the Auto Shuttle. They sweep the surface of the rail to ensure a clean running surface for the wheels.

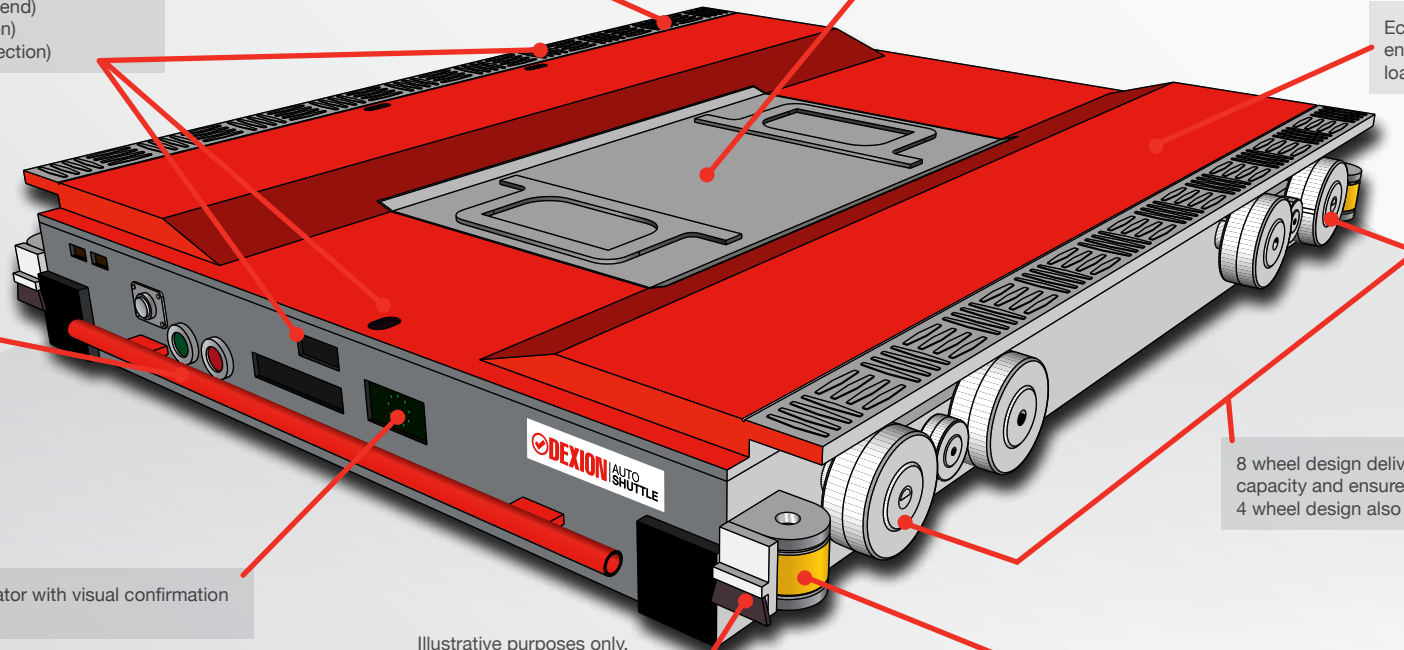

# How Auto Shuttle compares with other forms of warehouse storage.

The Auto Shuttle storage solution provides significant productivity and storage advantages compared to typical 'block stack' and 'drive-in' storage applications. The advantages of Auto Shuttle storage over other typical forms of warehouse storage are as follows:

	Auto Shuttle	Block Stack	Drive-In	Pallet Flo
Solution suitability	Storage solution is scalable to both capacity and task activity.	Stack suitability subject to product stackability, pallet quality and operator placement.	Risk of operator damage is high.	Risk of "jams" subject to pallet quality and pallet weight variability.
Stack height	Up to the limit of the MHE reach.	Normally 3-4 pallet equivalent. Stack height subject to product rigidity and stack stability.	Up to the limit of the MHE reach.	Up to the limit of the MHE reach.
Stack depth	Typically 10-15 deep, but can be deeper if product profile permits.	Dependent on available floor space and MHE access.	Typically up to 3 deep. Task productivity can slow and racking susceptible to operator damage with deeper designs.	Up to 10 deep, however pallets are subject to "jams" where pallet quality is questionable and/or there are differing pallet weights.
Selectivity	Channel	Stack	Channel	Channel
Task travel	Possible dual face put-away and retrieval. Depth travel not required.	Subject to stack depth and height for put-away and retrieval.	Single front face put-away and retrieval. Depth travel required.	Single front face put-away and retrieval. Depth travel not required.
Storage queuing	FIFO - Yes LIFO - Yes	FIFO - No LIFO - Yes	FIFO - No LIFO - Yes	FIFO - Yes LIFO - No
Product crush risk	No risk.	High Risk. Lower pallets susceptible to crushing. Suitability of storage method highly dependent on product strength and rigidity.	No risk.	No risk.

Note: Table is for a typical 1165 x 1165 pallet that is 1000-1200 high in a typical warehouse environment using standard MHE.