

# Selective Pallet Racking (Keylock & Speedlock) User Manual





## **KEYLOCK / SPEEDLOCK SELECTIVE PALLET RACKING**

# **USER INSTRUCTIONS**

This manual remains the sole property of Dexion (Australia) Pty Limited. It must not be copied without prior written consent and must be returned upon request. The information contained within this manual is to be regarded as confidential and must not be disclosed to any third party.

Whilst the utmost care is taken to ensure the accuracy of the data and design details shown within, Dexion (Australia) Pty Limited cannot, under any circumstances, be held liable for any injuries, expenses or loss which may, in any degree, be attributed to the use or adoption of such data and design details.

Any modification, repair, or alteration of Dexion products by a third party without prior written approval from Dexion Engineering Group voids Dexion's warranty obligations under the lifetime warranty.

© Copyright:

Dexion (Australia) Pty Limited  
22 Powers Road  
Seven Hills NSW 2147

Product Management  
Tel: +61 2 9830 5000  
Fax : +61 2 9830 5001  
E-mail : [Technical@dexion.com.au](mailto:Technical@dexion.com.au)

Date of Issue: September 2018



---

## TABLE OF CONTENTS

<b>TABLE OF CONTENTS .....</b>	<b>1</b>
<b>INTRODUCTION .....</b>	<b>3</b>
OPERATOR TRAINING .....	3
INSTALLATION DATA SHEET .....	4
GLOSSARY OF DEXION TERMINOLOGY .....	5
<b>THE PALLET.....</b>	<b>6</b>
PALLET TYPE AND SIZE .....	6
LOAD ON THE PALLET .....	7
PALLET WEIGHT .....	7
PALLET CONDITION .....	7
PALLET ILLUSTRATIONS .....	8
<b>THE FORK LIFT TRUCK (FLT) .....</b>	<b>10</b>
LIFT HEIGHT .....	10
CORRECT FORK LENGTH .....	10
TURNING CIRCLE .....	10
DRIVER TRAINING .....	10
DAMAGE TO STORAGE EQUIPMENT .....	10
CARE AND ATTENTION.....	11
<b>OPERATIONAL CLEARANCES.....</b>	<b>12</b>
LOAD ON THE PALLET .....	12
OPERATING CLEARANCES .....	12
MAINTAINING OPERATING CLEARANCES .....	12
AISLE WIDTH.....	13
<b>LOADING / UNLOADING THE SYSTEM.....</b>	<b>14</b>
PICKING UP THE PALLET .....	14
CORRECT LOADING/UNLOADING PROCEDURE .....	14
ACCESSING STORAGE LEVELS ABOVE THE GROUND .....	14
APPROACHING AND ENTERING THE RACK.....	15
UNACCEPTABLE PALLET HANDLING.....	15
LOADING THE SYSTEM.....	16
UNLOADING THE SYSTEM .....	17
CORRECT PLACEMENT OF LOADS.....	18
<b>CHANGES TO THE RACK SYSTEM.....</b>	<b>19</b>
<b>CLEANING THE INSTALLATION.....</b>	<b>19</b>
<b>ROUTINE INSPECTION / MAINTENANCE .....</b>	<b>20</b>
RACK SAFETY OFFICER / REPORTING PROCEDURE .....	20
COLOUR CODING FOR RISK IDENTIFICATION .....	20
INSPECTION INTERVALS.....	21

---

<b>DAMAGE TO THE STORAGE EQUIPMENT</b> .....	<b>22</b>
INTRODUCTION .....	22
COMPONENT RECOGNITION .....	23
REPORT ALL DAMAGE.....	23
REPLACE DON'T REPAIR.....	23
DAMAGE INSPECTION – BEAMS .....	24
DAMAGE INSPECTION – FRAMES .....	26
DAMAGE INSPECTION – RACK OUT-OF-PLUMB .....	27
<b>RISK ASSESSMENT</b> .....	<b>28</b>
GREEN RISK:.....	28
ORANGE RISK:.....	28
RED RISK:.....	28
DAMAGE ACTION PROCEDURE FLOWCHART .....	29
TYPICAL CAUSES OF DAMAGE .....	30
PRECAUTIONS AGAINST DAMAGE .....	30

## INTRODUCTION

**Keylock and Speedlock** are the product names for Dexion pallet racking systems.

**Keylock and Speedlock** are versatile storage systems allowing individual installations to be designed around the goods to be stored. This versatility enables best use of available space and height, with the correct strength of structure.

The systems comprise pairs of horizontal beams supported between vertical frames. Unit loads, or pallets can either be supported directly on these beams, or indirectly using secondary supports or accessories. Storage levels above the ground are accessed using mechanical handling equipment such as fork lift trucks that operate within an adjacent aisle or gangway. The systems also provide heavy-duty long span shelving by installing decking on the beams. A range of rack protection is available to help prevent against damage from handling equipment.

**These instructions describe the principles of the Keylock and Speedlock pallet racking systems, how to safely operate the racking, damage recognition, inspection, maintenance, etc. The guide does not go into the specifics of individual installations.**

## OPERATOR TRAINING

Dexion recommends that ALL personnel operating within a warehouse environment are trained in safe working practices by trained and approved Dexion personnel only.

Part of the training given to forklift truck drivers should include the correct use of the **Keylock or Speedlock** installation. This should include the recognition of pallet types, checks on suitability, the correct method of loading and unloading the racking and the recognition of defects or damage that could adversely affect safety.

These guidelines describe how to use the system safely and should form part of your training. A copy of this document should be made available to all drivers.

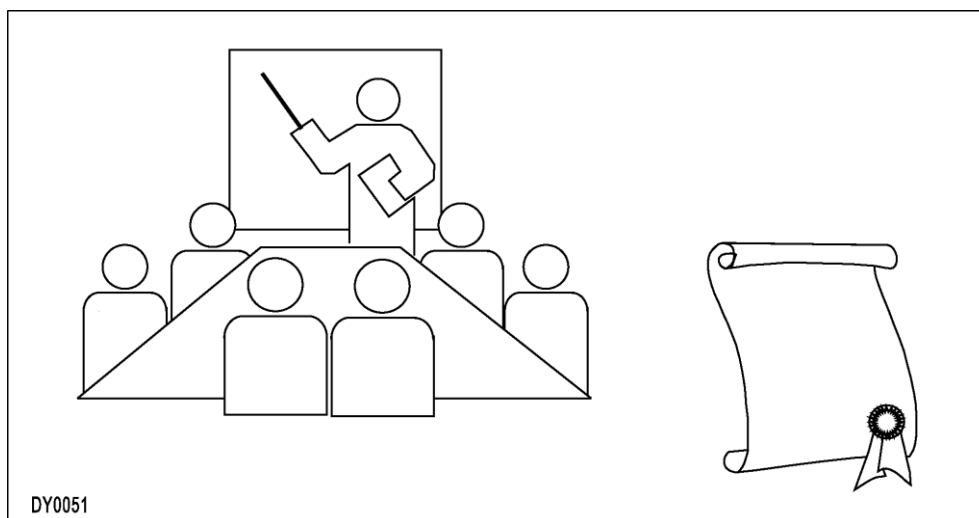

To ensure safe use of the storage equipment, the user must understand the following points:

**Use of the equipment**

The installation must be used in accordance with the specification and the criteria used for the design of the rack. The duty of the rack components will have been specifically selected to meet the individual load requirements of each rack. **It is important that these are not exceeded and that the rack is not altered without consultation.**

**Installation**

The storage equipment must be built in accordance with the specification, plans, and assembly instructions.

**Floor**

The warehouse floor, which is the racking foundation, must be capable of withstanding the upright loads and of receiving the baseplate floor fixings. It must have a suitable degree of surface level tolerance and flatness.

**INSTALLATION DATA SHEET**

Your installation has been designed around a pallet with the following characteristics.

<i>Client:</i>	<input type="text"/>	
<i>Date of Installation:</i>	<input type="text"/>	
<i>Dexion reference:</i>	<input type="text"/>	
<i>Block Ref. or Rack Area:</i>	<input type="text"/>	
<i>Pallet Type:</i>	<input type="text"/>	
<i>Pallet size:</i>	<b>x</b>	<i>mm.</i>
<i>Pallet handled on the:</i>	<input type="text"/>	<i>mm face.</i>
<i>Load size (left to right)</i>	<input type="text"/>	<i>mm.</i>
<i>Load size (front to back)</i>	<input type="text"/>	<i>mm.</i>
<i>Any load overhang must be even on both sides.</i>		
<i>Pallet + Load Height:</i>	<input type="text"/>	<i>mm.</i>
<i>Pallet Load:</i>	<input type="text"/>	<i>Kg maximum.</i>

**NOTE:** For “Supply Only Orders”, the end user is advised to follow Dexion’s relevant Installation Procedure, fill out appropriate information and retain this form as reference.

## GLOSSARY OF DEXION TERMINOLOGY

The following terms are referred to within this guide.

Adjustable pallet racking (APR)	A system of horizontal beams supported between vertical frames that provide raised storage levels. These levels being adjustable within the height (within acceptable limits).
Allowable loading:	The safe load capacity of the structure, i.e. beams, frames.
Bay:	A proportion of the rack separated by adjacent support frames, includes all levels within the height.
Compartment:	A single storage level within a bay of racking.
Compartment load:	The total allowable weight of all unit loads within a compartment.
Fork lift truck:	Either of a counterbalance or reach variety. The truck has a mast with elevating forks, used to access pallets stored above ground level.
Design clearances:	The clear spaces either side and above the load. These clearances provide space in which to safely handle the load without contact with surrounding pallets or rack structure.
Total rack load:	The total allowable weight of all unit loads supported on beams within a run of racking.
Unit load:	The weight of a single unit that can be placed in one operation. Example the weight of a single pallet.
Wide aisle racking:	Pallet racking arranged to leave aisles of sufficient clearance width to allow fork lift equipment to traverse the length of the aisle and make 90° turns into the rack face for loading and unloading. Trucks are usually of the counterbalance type, with aisles generally in the range of three to four metres wide.
Narrow aisle racking:	Pallet racking arranged in a similar way to wide aisle racking but having aisles of reduced width. Trucks are usually of the reach type with aisles generally in the range of two to three metres wide.
Very narrow aisle racking:	Pallet racking arranged with aisle widths to cater only for the pallet and truck plus a small (200-600mm) operating clearance. Pallets are handled without the need for the truck to turn bodily into the rack to either load or unload. Trucks are usually guided into and along the aisle by guide rails or wire guidance systems.
Stop the truck:	The expression “stop the truck” means that the drive is neutralised and the brake is applied.
Drive slowly:	The expression “drive slowly” means travelling at a speed not exceeding 2.5km/h.
2 way entry pallet:	A pallet with only fork access on two (opposing) sides.
4 way entry pallet:	A pallet with fork access on all four sides.



---

## THE PALLET

The following gives general information about the pallet.

### PALLET TYPE AND SIZE

Your **Keylock / Speedlock** rack will have been designed around a specific pallet style and dimensions; this will be detailed within “**The Installation Data Sheet**” on page 4.

**The most common and widely used in Australia is the wooden 2-way Standard (CHEP) pallet.** Other industrial pallets have also been illustrated on the following page to aid identification.

- The Australian Standard (CHEP) Pallet 1165 x 1165
- European Pallet: EUR 800 x 1200mm
- Industrial: IND (Fin-pallet) 1000 x 1200mm
- The (UK) GKN CHEP pallet 1000 x 1200mm

The Australian Standard pallet is a 2-way entry pallet, which is normally handled on either of the two opposing sides where the end of the bearers are exposed (refer to the pallet illustration). The other industrial / European pallets can be handled on either the long or short face, which make them known as ‘four way entry’ pallets.

Whichever is chosen, it is important that the orientation is maintained, as the rack dimensions will have been designed for that style of handling, and where necessary the correct accessories will have been included. **Also note that mishandling of the pallet by depositing it the wrong way round could result in pallet failure and even injury.** An example would be handling the EUR 800x1200 or IND 1000x1200 on the long side and depositing it on a pair of pallet beams (without pallet support bars) and only front and rear bearers are supported lengthways.

**Note:** **Whichever pallet your installation has been designed for, it is important that only the correct pallet be entered into the installation. It is dangerous to mix or enter any other pallet style or size other than those the system has been designed for.**

---

## LOAD ON THE PALLET

The stability of the load on the pallet is important. Ideally loads will be shrink-wrapped or banded in preference to loose stacking. There should not be any loose wrapping or banding on the bottom of the pallet. Interlocking of individual items is better than an un-structured placement.

Any load overhang (if permitted) should be even on both sides of the pallet.

Ideally loads should be perpendicular and not lean, however this is rarely practical and the following deviation is acceptable:

Pallet height up to 2000mm: Max. 1% of the pallet height.

Pallet height between 2000 and 3000mm: Max. 20mm.

## PALLET WEIGHT

The pallet weight is the combination of the 'self-weight' of the timber pallet + 'load'.

The load must be evenly distributed across the whole area of the pallet to avoid any potential uneven loading of the rack.

**Do not enter pallets with weights that exceed the permitted limit.**

## PALLET CONDITION

Pallets must be in good condition, and free from damage. Pallets with loose or broken boards, or protrusions should NOT enter into the system.

It is important that the pallet can safely support itself (with load) when spanning between the beam supports.

If the strength of the pallet is in doubt, a simple test can be conducted to check its suitability.

Support the pallet a little off the ground using timber battens along its edges, to simulate the supports. Overload the pallet by 25% and leave for 24hours. If the pallet has suffered no harmful distortions after this time it can be considered suitable.

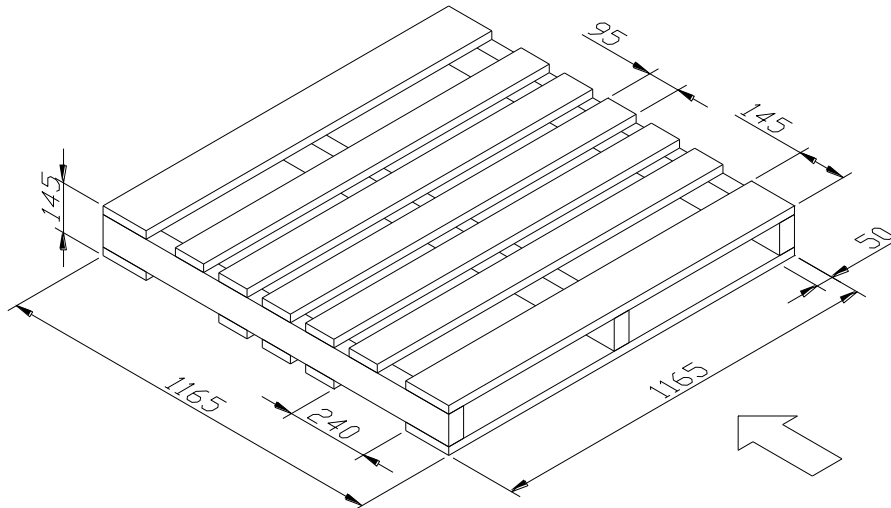
**PALLET ILLUSTRATIONS**

**Australian Chep Wooden Pallet  
(1165x1165x145)**

The Australian standard pallet has a square base of 1165mm (W) x 1165mm (D) with a maximum height (H) of 150mm. The minimum clear entry height between bearers is 90mm. The pallet is a 2-way entry pallet. The figure shown below is a view from the pallet bottom of a modified pallet with cut-out bearers for 4-way entry. It is a common practice for standard racking applications to have a frame depth of the size (e.g. 838mm frame) where a pair of beams will be locked in between the pallet bottom planks (i.e. 240mm gaps). The feature not only secures the pallet on beams but also minimises the chance of overloading the rack due to unsymmetrical loading in the front to back direction.

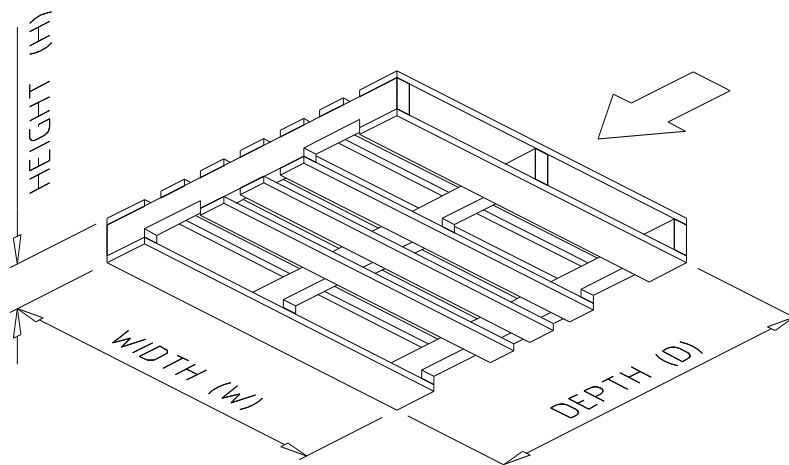

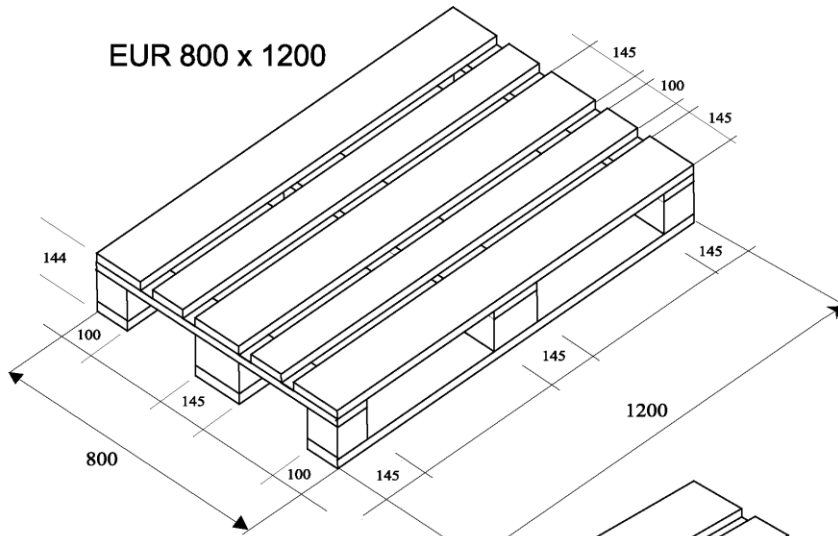

**IND 1000 x 1200**  
(Industrial/Fin pallet)

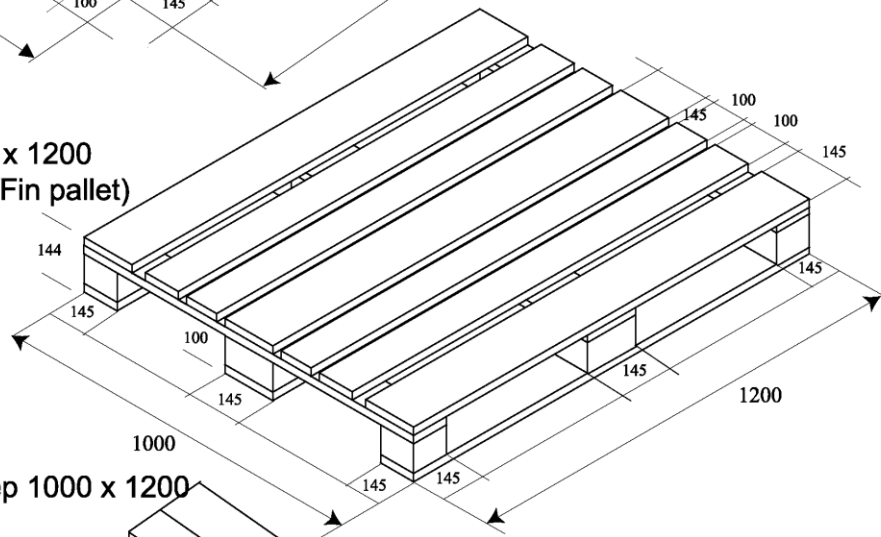

**The (UK) GKN Chep 1000 x 1200**

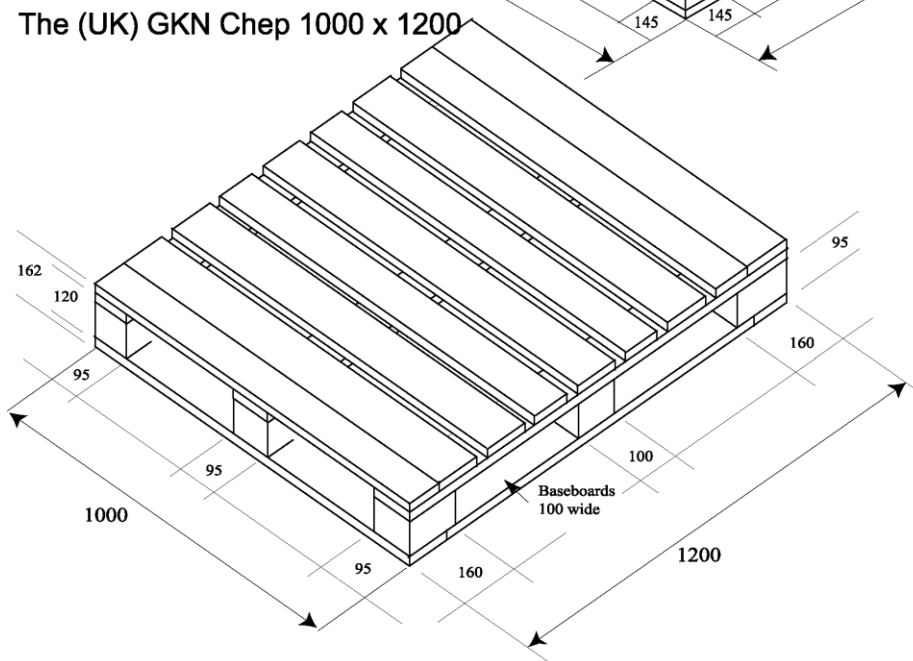

SL0181

## THE FORK LIFT TRUCK (FLT)

The fork lift truck must be of a suitable design and capacity, capable of lifting the loads to the heights required. If there are any doubts regarding its capacity, reference should be made to the relevant manufacturer or supplier.

### LIFT HEIGHT

The truck must be capable of lifting the pallet clear of the top storage level by at least 100mm.

### CORRECT FORK LENGTH

The forks should be of sufficient length to support all the boards, but not extend beyond the pallet (refer to the right-hand side figure for correct fork length).

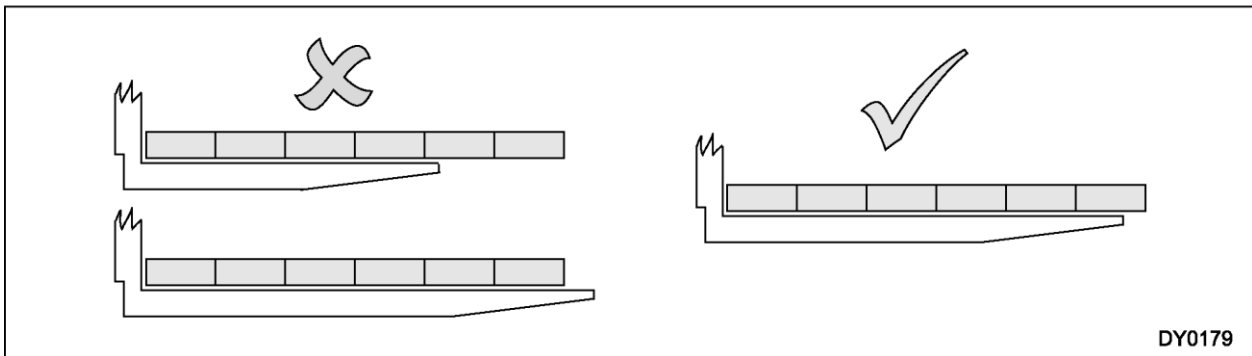

### TURNING CIRCLE

The fork truck with combined load must be capable of operating within the aisle widths provided.

### DRIVER TRAINING

All fork truck drivers should be suitably trained and licensed in the operation of the handling equipment. Secondly, they should be trained in the use of this type of storage system and have a copy of these instructions available to them.

### DAMAGE TO STORAGE EQUIPMENT

The user is responsible for ensuring that the handling equipment is driven carefully at all times to avoid any collision with, or damage to the rack structure.

## CARE AND ATTENTION

The following sections of guidelines cover the correct use of the system, and how to load and unload the racking.

Following these recommendations and procedures, i.e. pallet inspection, correct pallet placement and alignment, will all help the efficiency and smooth operation of the system helping to prevent problems.

Adversely, harsh treatment or abuse will soon lead to damage and a reduction in system reliability and performance, and in extreme cases render the structure unsafe.

For the benefit of the system and personnel "Adopt and Maintain Safe Working Practices".

## OPERATIONAL CLEARANCES

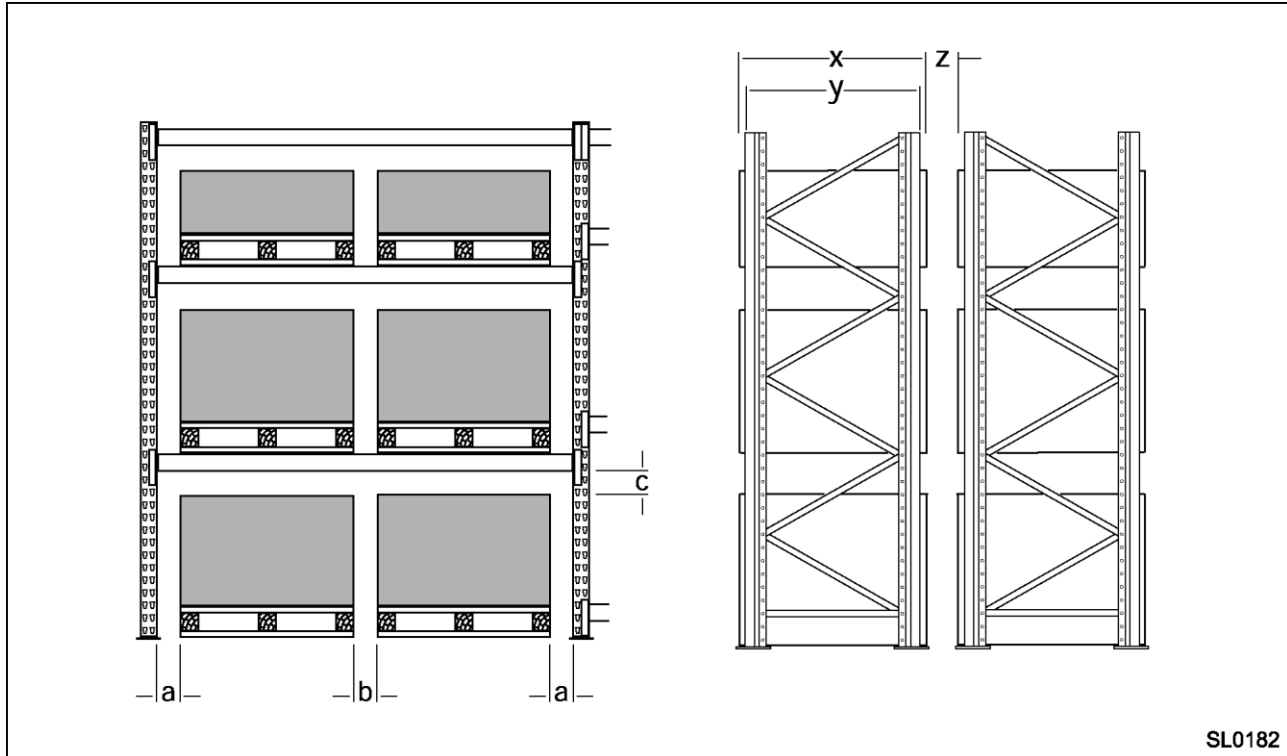

### LOAD ON THE PALLET

The load should be stacked centrally on the pallet, and if overhang has been permitted within the design, the overhang should be even on both sides of the pallet.

### OPERATING CLEARANCES

The rack dimensions will have been designed to provide operating clearances between the pallet and the adjacent rack structure or adjoining pallet/s. The amount of recommended clearance varies slightly according to the rack height and the type of handling equipment in use. These recommendations have been judged to provide the operator with a fair margin in which to handle and position the pallet.

### MAINTAINING OPERATING CLEARANCES

It is important to maintain operating clearances to ensure safe working practices. A loss of clearance leads to an increased risk of damage to the rack structure, and a reduction in fork truck driver efficiency. The following can cause reductions in clearances:

- Storing an oversized pallet.

- Storing a pallet with load overhang when the design doesn't allow for it.

- Misplacing the first pallet, thereby not allowing sufficient space for subsequent loads.

- Misplacing floor level pallets so that they protrude into the operating aisle.

- Storing a pallet that has been picked up out of alignment.

## **AISLE WIDTH**

The effective aisle width is the width between stored pallets, which is often less than the rack to rack dimension because the pallets overhang into the aisle. Fork truck manufacturers provide recommended aisle widths for specific truck types and load sizes. These recommendations often provide varying allowances of clearance, and it is worth considering if sufficient clearance has been included. Note: Any change in truck type used in the installation will require a check to determine that the aisle width is still adequate.



## LOADING / UNLOADING THE SYSTEM

The warehouse should be adequately lit, to permit the safe use of fork lift trucks and the handling of pallets.

### PICKING UP THE PALLET

The pallet must be picked up square to the forks; any misalignment of the pallet on the forks can't be corrected during the placement sequence and results in badly placed pallets within the system. Misalignment also increases the effective size of the pallet, leading to a reduction in operating clearances.

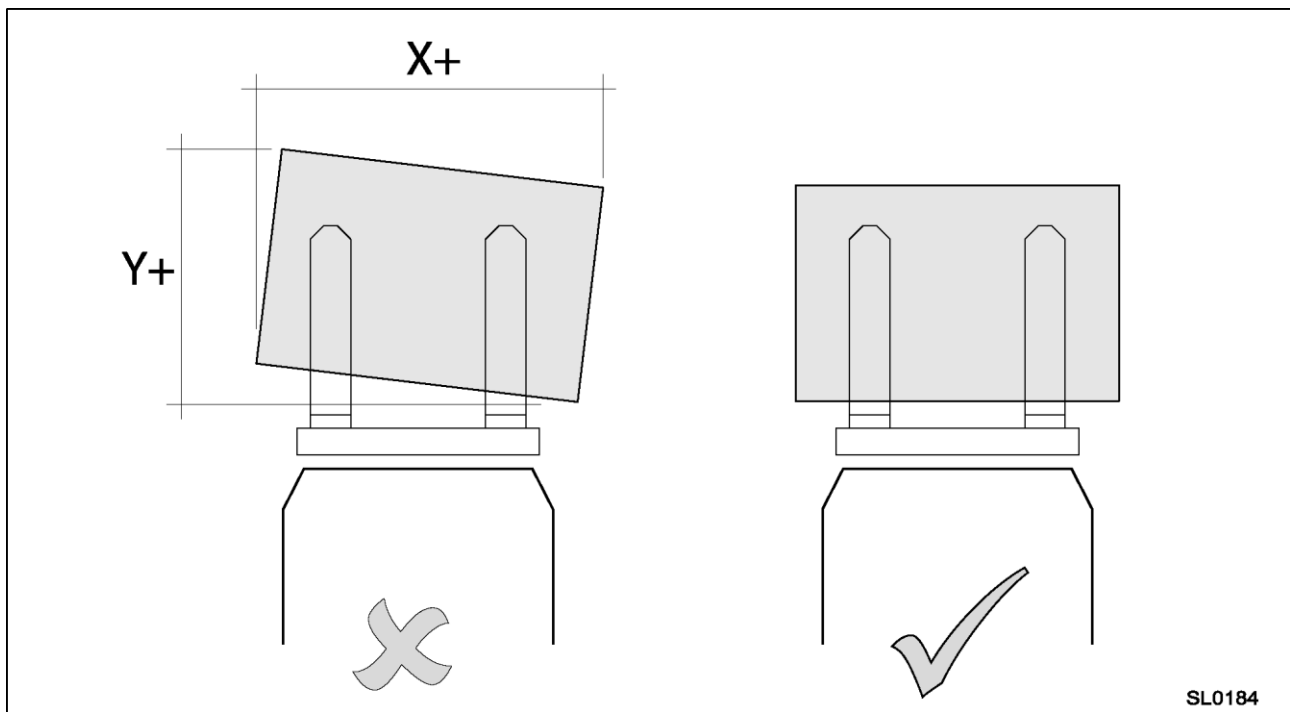

### CORRECT LOADING/UNLOADING PROCEDURE

The following pages detail the correct procedures for loading and unloading the racks.

### ACCESSING STORAGE LEVELS ABOVE THE GROUND

When accessing raised levels the correct equipment must be used.

## APPROACHING AND ENTERING THE RACK

The fork lift truck should approach the rack squarely and not at an angle. No attempt should be made to deposit/retrieve pallets when the truck is NOT correctly aligned. It is not acceptable to attempt to re-align a pallet after entry into the rack.

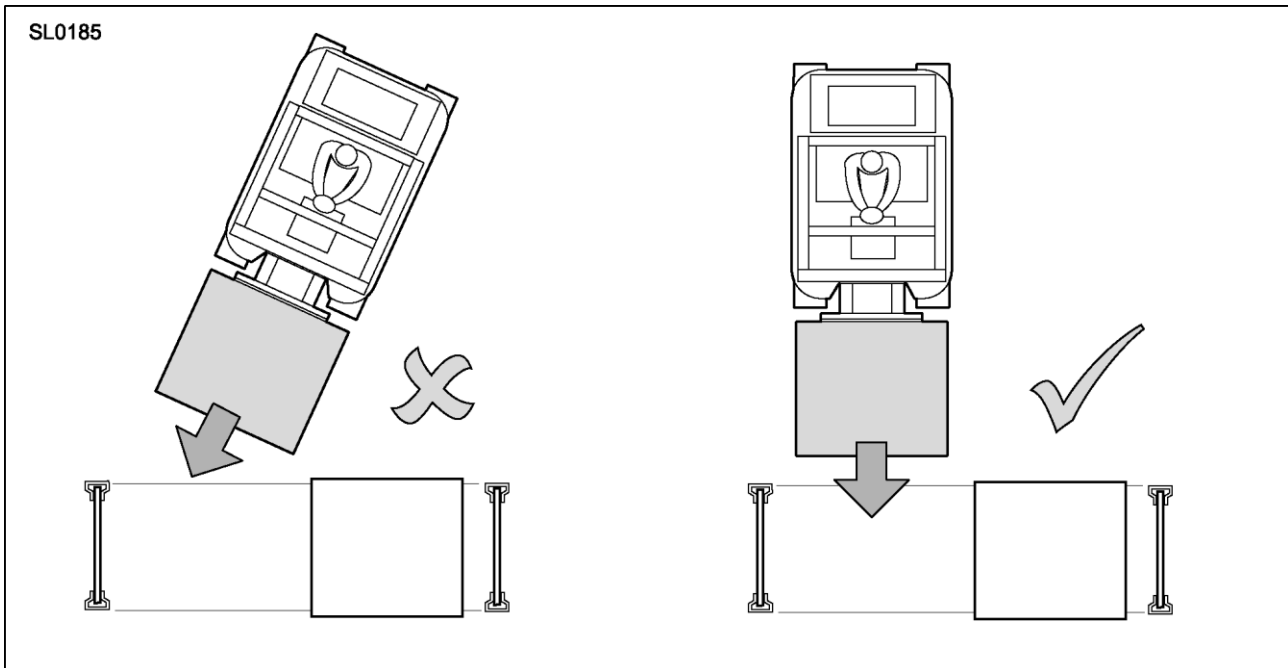

## UNACCEPTABLE PALLET HANDLING

It is not acceptable practice to:

- Nudge one pallet with another, in an attempt to move or re-align loads.
- Drag or slide pallets on or against the support beams or structure.
- Position or locate a pallet by nudging an adjacent pallet.

All of these are dangerous practices that impart additional loads in the rack structure, and could lead to damage and a reduction in safety. All are avoidable if the correct procedures are adopted.

## LOADING THE SYSTEM

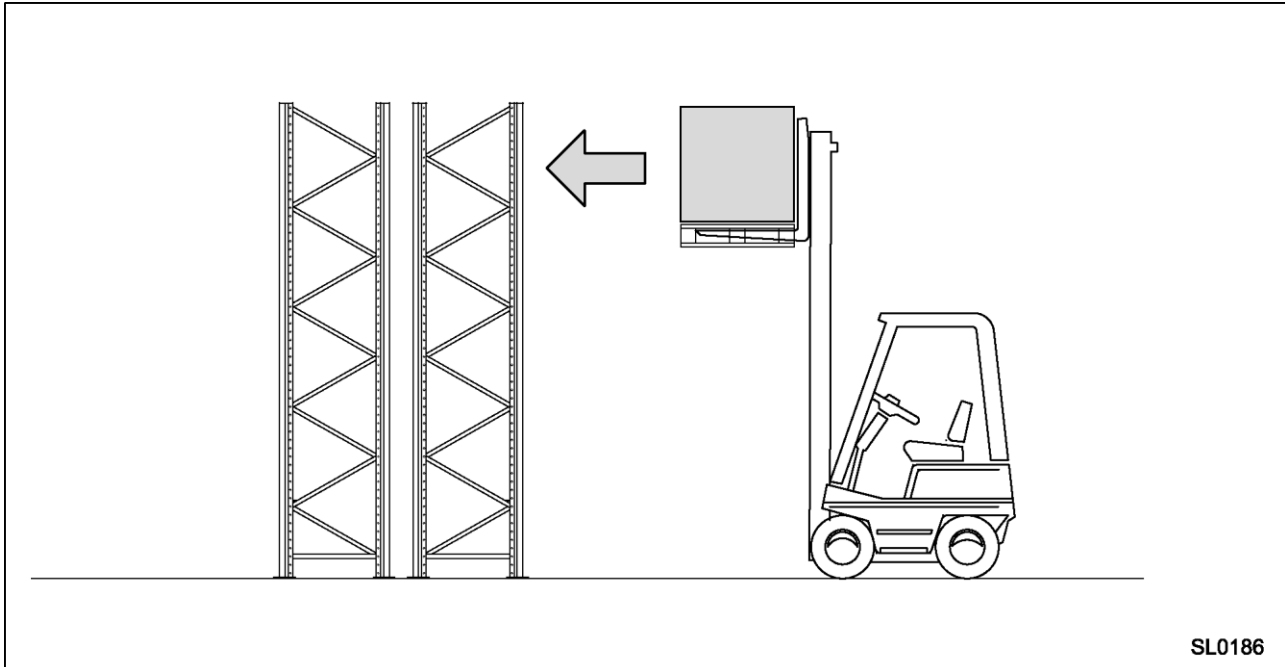

SL0186

- Step 1 Check that the pallet is the correct style and size for the installation.
- Step 2 Check the underside of the pallet for loose, split or damaged boards. Damaged pallets should not be entered into the racking.
- Step 3 The fork lift truck driver inserts the forks into the pallet, and picks the pallet up ensuring that it is square and that the forks are evenly spaced within the pallet. Any skew in the pallet at this stage cannot be corrected and will remain when the pallet is placed in the rack.
- Step 4 The fork lift driver manoeuvres the truck and pallet, approaching the rack squarely aligning the pallet and truck centrally with the desired storage location.
- Step 5 Slow down and stop the truck in front of the desired location. Reduce any tilt on the mast and raise the pallet to the required storage level, ensuring the pallet is still aligned centrally.
- Step 6 Correctly position the pallet within the depth of the rack with regard to the pallet rack beams. Ensure no contact is made with the adjoining rack structure before lowering the pallet.
- Step 7 Carefully lower the pallet onto the support beams and release the load from the forks. Once in contact with the support beams, the pallet must not be slid or dragged along or across the structure.
- Step 8 Remove the forks from the pallet and lower them to the ground.

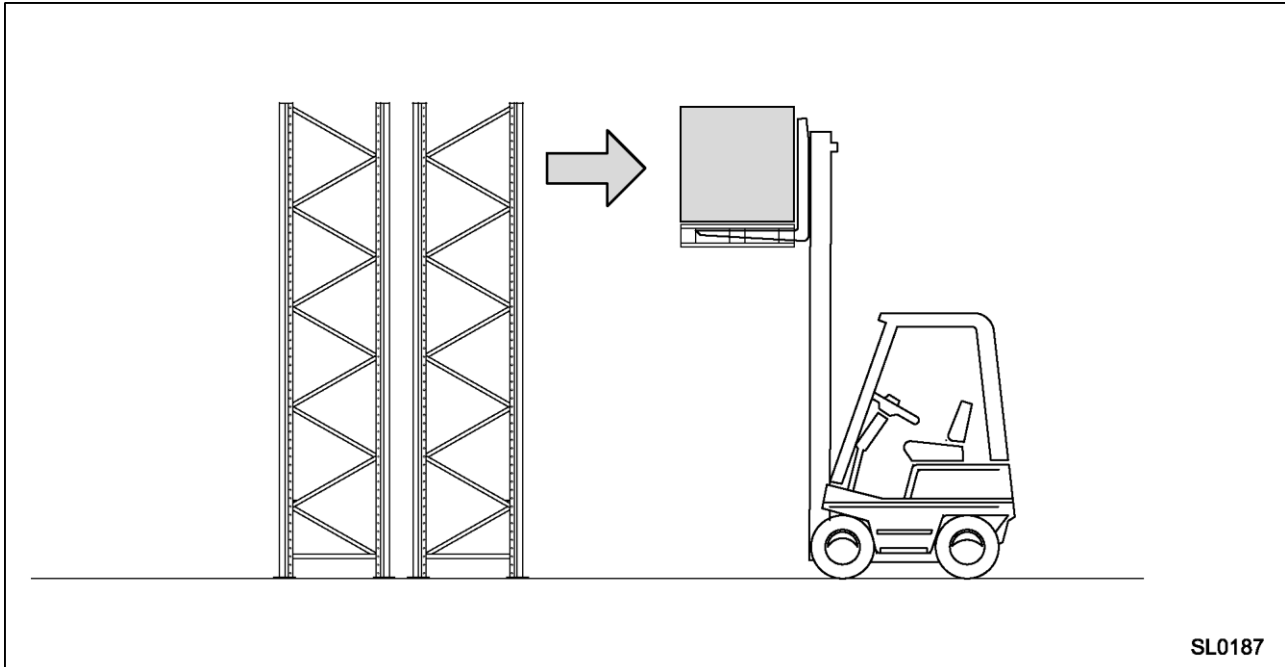
**UNLOADING THE SYSTEM**

- Step 1 Approach the rack squarely and align the truck centrally with the desired location.
- Step 2 Slow down and stop the truck in front of the desired location. Reduce any tilt on the mast and raise the forks to the required storage level ensuring the truck is still aligned centrally.
- Step 3 Insert the forks into the required pallet.
- Step 4 Carefully lift the pallet just clear of the support beams, ensuring it is not raised too far thus hitting the beam level above.
- Step 5 Remove the pallet clear of the rack before lowering the forks to the correct travelling position before moving off.

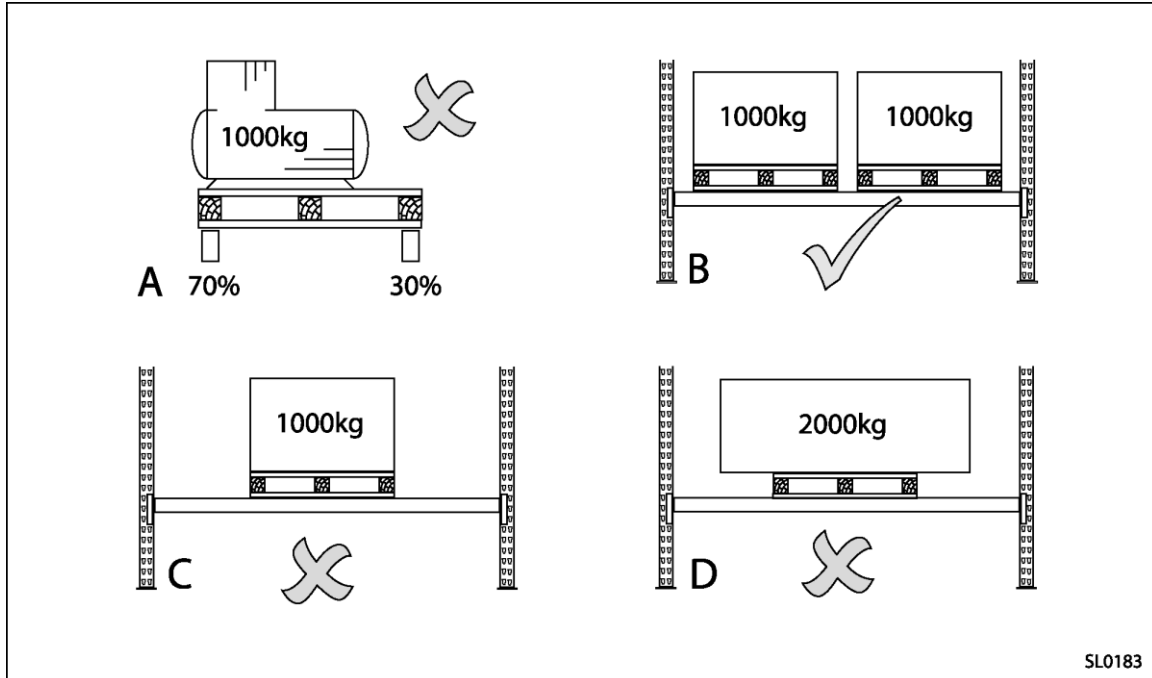
**CORRECT PLACEMENT OF LOADS**

Timber pallets must be placed in the rack so that the pallet bearers span the space between the beams. The bearer may be a one piece construction or a composite construction of top and bottom boards spaced apart with blocks. Composite construction pallets must be supported directly under their blocks to prevent breaking the bottom boards.

Care should be taken to ensure pallets are positioned correctly to prevent any potential overload conditions.

The above graphic, based on typical 1000kg unit loads, show examples of **correct** and **incorrect** positioning of pallets

- Example A The load on the pallet must be evenly distributed across the whole area of the pallet to avoid any potential uneven loading of the rack between the front and rear beams.
- Example B The correct positioning of two 1000kg loads within a 2000kg compartment. This is an example of good loading practice.
- Example C This is an example of a badly positioned pallet. Although not an overload condition, it does prevent the storage of a second pallet and is not good working practice.
- Example D This is an overload condition. The illustration shows the central positioning of a single 2000kg pallet that will overload a pair of beams designed for two 1000kg pallets.

---

## CHANGES TO THE RACK SYSTEM

A change in a rack configuration will cause a change in the load carrying capacity of a rack.

In both braced and unbraced racking, if the height to the first beam level or the space between beams is increased, the safe load capacity of the frames will be reduced.

The following points should be observed:

1. In all cases of changes Dexion should be consulted before any alterations are made.
2. Additions or changes to the storage equipment by welding or bolting are not permitted unless specifically approved by Dexion.
3. Racks that are braced longitudinally will have a higher load carrying capacity than a similar unbraced structure built of the same components. The removal or faulty rearrangement of any bracing will substantially reduce the load carrying capacity of the installation.
4. In the case of longitudinally braced racks, any alteration in beam levels will require a similar change in the positioning of the bracing.
5. Changes in the safe load carrying capacity of the rack may occur if the racks are re-located and the floor conditions supporting the equipment change.
6. Safe load notices must be replaced as necessary after changes to the rack configuration.
7. During any alteration, for safety, the rack must be unloaded.
8. Changes should only be made in a professional manner and in accordance with the supplier's instructions.

## CLEANING THE INSTALLATION

Should the rack need cleaning, either as part of a routine, or as a result of a spillage, the following guidelines should be observed.

The clean should comprise of a wipe down with a damp cloth, using (if required) a mild detergent. NEVER use a hose to spray the racking. NEVER use abrasive or caustic cleaning agents.

## ROUTINE INSPECTION / MAINTENANCE

It is recommended that the end user refer to **Section 9 - “Operation and Maintenance of Adjustable Pallet Racking”** of **AS4084 (Steel Storage Racking)** for racking inspection and maintenance procedures. As a supplement to the code recommendation, the following information has been compiled based on AS4084 and the FEM recommendations. For your information, **FEM (Federation Europeenne de la Manutention)** is a European industrial body made up from various national organisations representing the storage equipment manufacturers in their own country.

The “**Keylock and Speedlock**” systems require no maintenance, other than to replace possible damage through incorrect operation. The system should be regularly inspected.

## RACK SAFETY OFFICER / REPORTING PROCEDURE

It is recommended that a ‘Rack Safety Officer’ is appointed and a procedure put in place so that any damage or unsafe occurrences can be reported, thus ensuring that any necessary actions can be taken to maintain a safe working environment.

The safety officer would undertake routine inspections, keeping maintenance and safety reports.

## COLOUR CODING FOR RISK IDENTIFICATION

The following colour coding; Green, Amber, and Red are classifications of risk as defined by the **FEM ‘Guidelines for the Safe Use of Static Racking’**

- Green Risk:** Damage requiring surveillance.
- Orange Risk:** Hazardous damage requiring action as soon as possible.
- Red Risk:** Very serious damage requiring immediate action.

See section on risk assessment.

## INSPECTION INTERVALS

### Daily Inspections

This applies to operator care of the system.

- Ensure the correct application and use of equipment.
- Ensure that the safe working loads are adhered to.
- Damaged pallets must not be entered into the system and should be removed as they occur.
- Any safety issues or damage to the structure should be reported to the Safety Officer, who will carry out the risk assessment and identify the risk as necessary.

### Weekly Inspections

The Safety Officer will perform a visual inspection carried out from ground level of all the racking. This should include all forms of accidental damage classed as **Red** or **Amber Risks**.

### Monthly Inspections

This should be carried out in a similar manner to the weekly inspection, but include the physical emptying of random bays in order to carry out a more detailed inspection.

- It should also be used to check that items already identified as **Red Risk** have been isolated with the necessary actions taken to rectify the risk. Similarly **Amber Risk** items should be checked to ensure repairs are underway.
- Ensure that all safe working load signs, maintenance and other safety signs are in place.

### Six to Twelve Monthly Inspections

A major inspection by a technically competent person, fully experienced in the identification and categorisation of rack damage. Such a person may be an external specialist capable of giving an independent assessment of the racking. This review should also examine the performance of the reporting procedures and that actual repairs are being carried out.

The inspection should be comprehensive and include checking for out-of-plumb areas and ensure that the rack installation has not been altered. A copy of the load application and configuration drawings shall be retained for this purpose.



The following pages detail the damage identification procedure and the risk assessment using colour-coding method as per FEM.

## DAMAGE TO THE STORAGE EQUIPMENT

### INTRODUCTION

Include reference to the use of Dexion Authorised or equivalent rack inspector.

Almost all damage to pallet racking is a result from a collision by a fork lift truck, or from the pallet the truck is transporting.

Any damage will reduce the ultimate load carrying capacity of the rack to some degree, thereby eroding the design safety factors. The greater the damage, the greater the reduction in the safety factor, until ultimately a collapse could occur at normal working load.

It is important that the user is aware of this situation and understands the need to monitor the racking carefully to ensure any damage is identified and dealt with.

The following is a summary of both AS4084 and FEM recommendations. Clearly it is not feasible to reproduce the whole documents in full within these instructions, and therefore if more detail or clarification is required, a separate reference should be made to those documents.

### Example of damage

The following are two examples of damage by a fork lift truck. In both cases the damage resulted in a reduction of about 30% to 40% in load carrying capacity.

Both users should consider themselves very fortunate that neither resulted in a collapse.

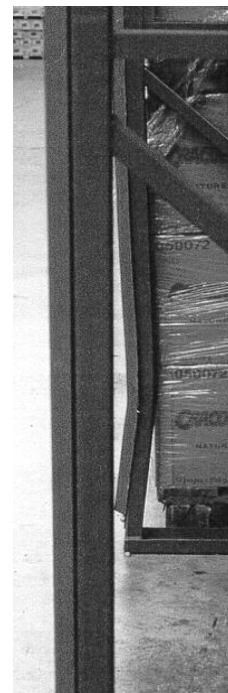

## COMPONENT RECOGNITION

The racking installation comprises two main elements:

Beams, comprising the beam section, end connectors and safety locks.

Frames, comprising uprights, bracing and baseplates.

Each should be inspected to the following recommendations.

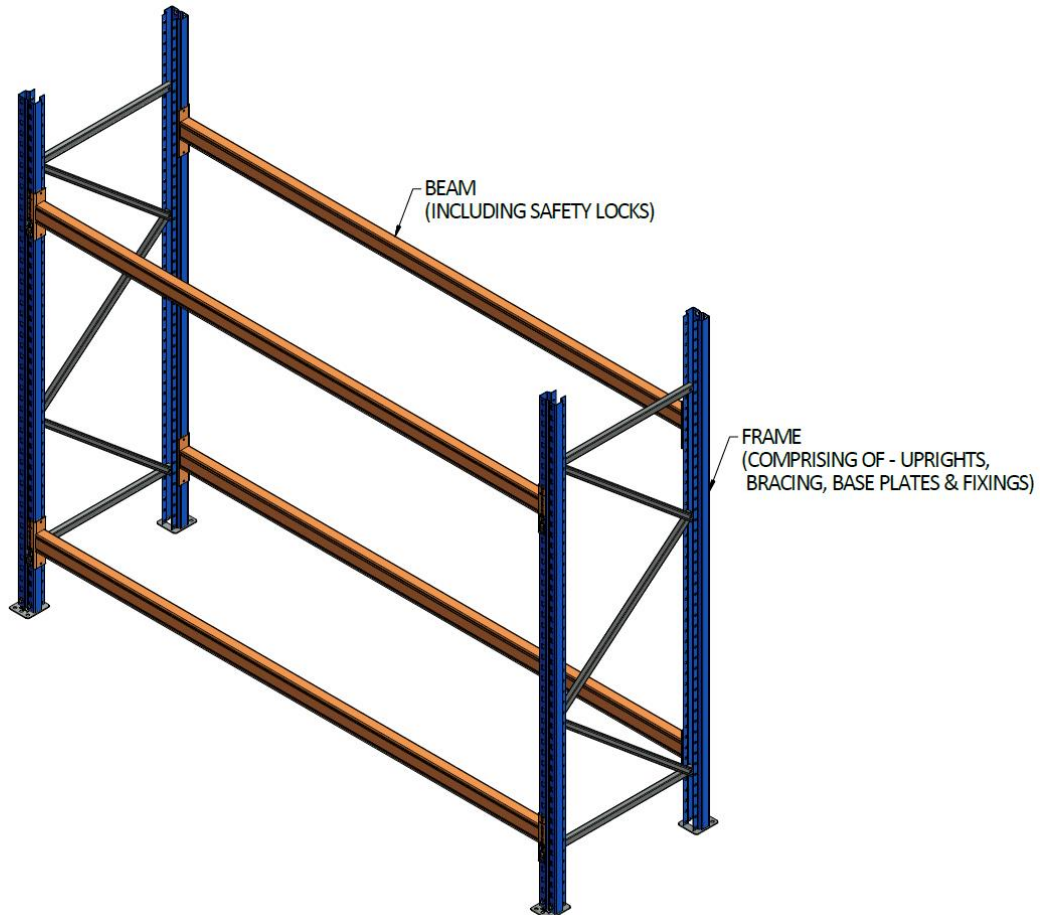

## REPORT ALL DAMAGE

If the racking is damaged it should be reported immediately to ensure the necessary precautionary actions are taken.

## REPLACE DON'T REPAIR

It is not recommended to repair damaged rack components.

Any component no longer fit for use should be replaced on a like for like basis.

If the bottom portion of an upright is damaged, replace the whole upright up to the original splice level. Never cut and splice in a small piece of upright.

Never apply heat in an attempt to straighten bent components.

**Remember: Replace don't Repair**

## DAMAGE INSPECTION – BEAMS

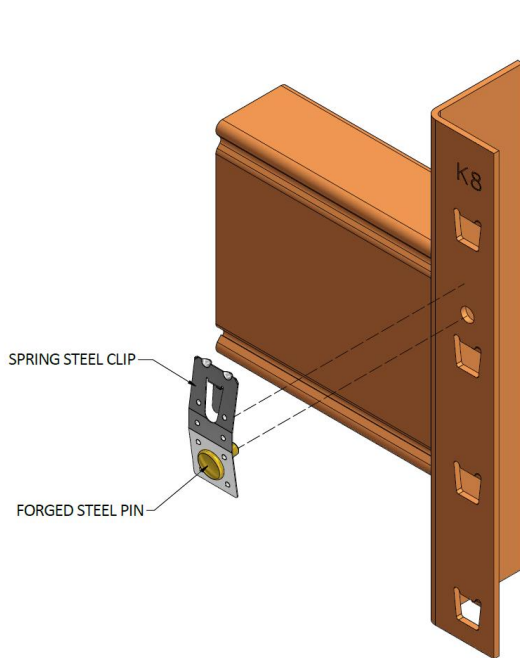

KEYLOCK CONNECTOR

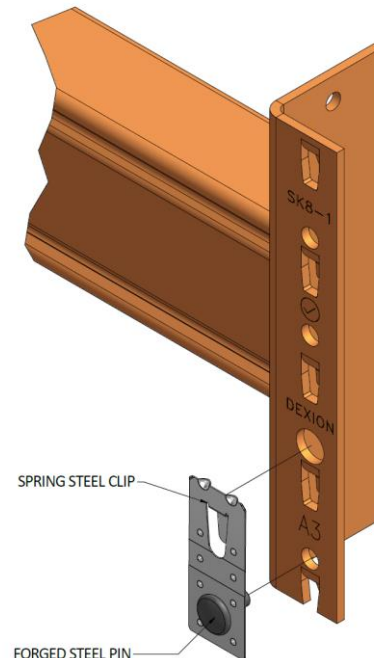

SPEEDLOCK CONNECTOR

### Safety Locks

Missing:

Replace immediately

Disengagement:

Reposition immediately, when correctly positioned the pin should pass through the lock hole in the connector and through the top of an upright slot.

Damaged upright slot:

The safety lock pin may damage the top of an upright slot, if the beam has been raised. If damage has occurred the beam should be repositioned (up or down) on the upright so that the pin fits through an undamaged slot.

### Beam End Connector

Connector:

Any damage, replace the beam immediately. If the upright slots are also damaged, these slots should not be reused for beam location.

Weld:

Any sign of cracking or lift of the weld, replace the beam immediately.

**Beam Section**

- Shape: Any damage which affects the section shape, replace the beam immediately.
- Deflection: If the vertical beam deflection is more than **SPAN/180** the beam is overloaded. Remove the load and check against permissible load data.
- Permanent Set: If the beam is permanently deformed when unloaded it has been overloaded. A straightness tolerance in vertical direction of 1 in 900 is permitted. If the unloaded beam has set more than **SPAN/900**, it must be replaced.

Similarly, a tolerance of **SPAN/360** is permitted in the horizontal direction.

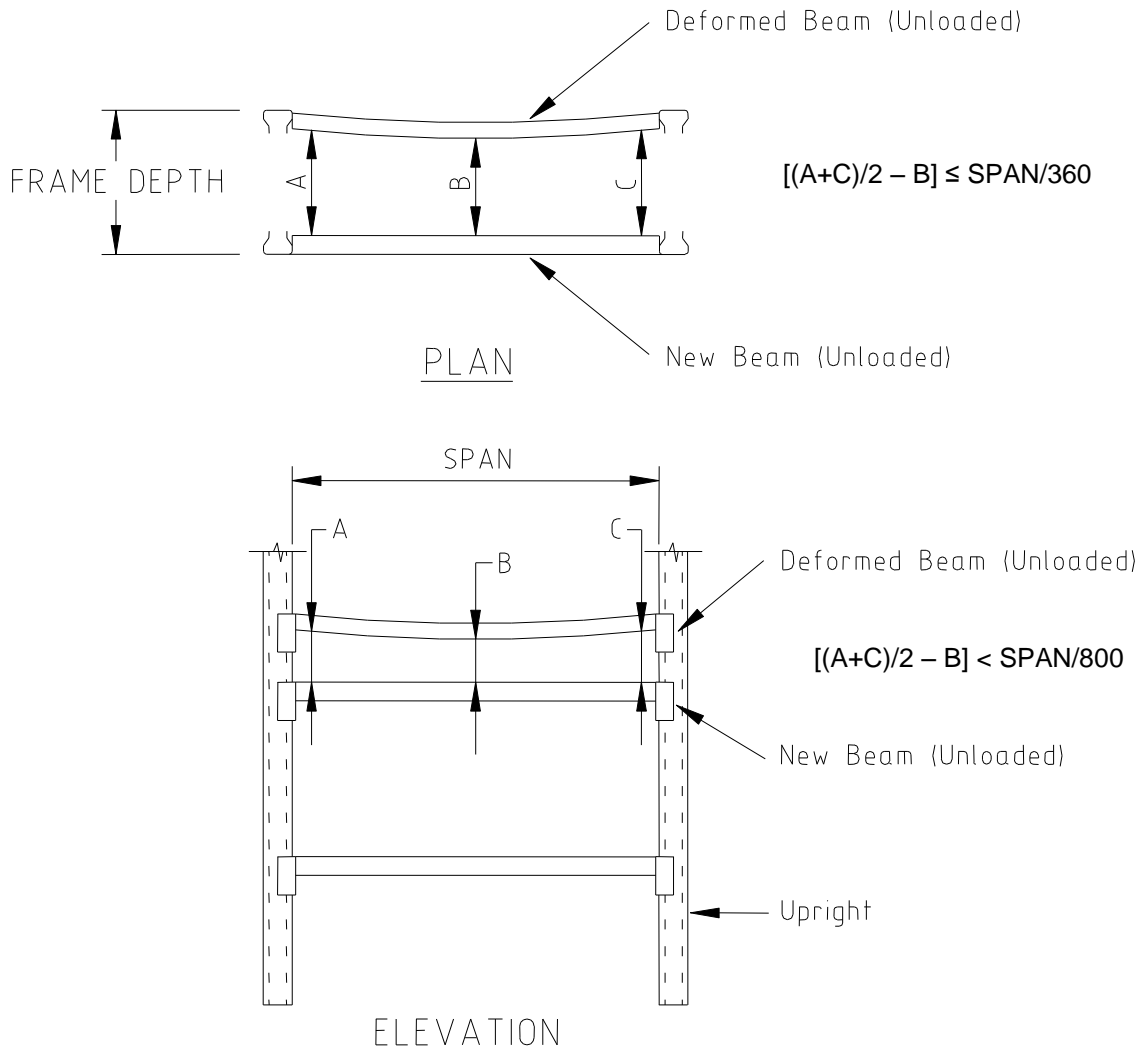

## DAMAGE INSPECTION – FRAMES

FEM quantifies damage to frame uprights and bracing as either Green, Orange or Red risk.

These rules only apply to damage that produces an overall bend in a component. They do not apply to highly localised damage such as **dents**, **buckles**, **tears** and **splits**.

Bends are judged against a 1000mm straight edge, localised bends over a shorter length should be judged pro-rata, i.e. for over a half metre length, half the limit applies.

Members subjected to tears and splits should always be replaced.

### Method of measuring damage:

1. A 1000mm steel straight edge is placed against the flat surface on the concave side of the damaged component, such that the damaged area lies equidistant from both ends.
2. For an upright bent in the direction of the rack beams, the maximum gap should not exceed 5mm.
3. For an upright bent in the direction of the frame bracing, the maximum gap should not exceed 3mm.
4. For an upright that has been damaged in both directions, the damage shall be measured and treated separately and the appropriate limits observed.
5. For bracing members bent in either plane, the maximum gap should not exceed 10mm. Pro-rata for bracing members that are less than 1000mm long.

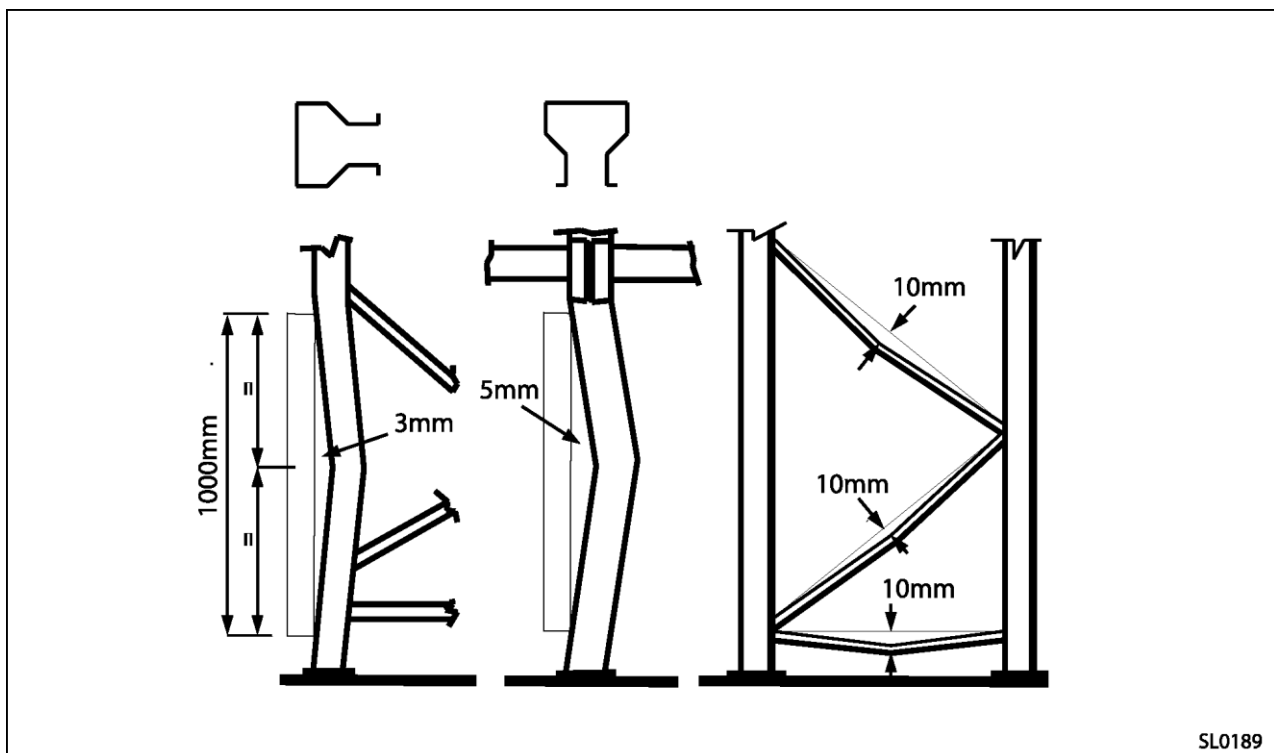

### DAMAGE INSPECTION – RACK OUT-OF-PLUMB

Due to an impact (e.g. fork truck collision), a rack may be out-of-plumb by a certain amount. A recommended maximum amount of out-of-plumb for a rack in **an unloaded condition**, both along the aisle and across the aisle directions, is **Height/350**.

A simple way to measure the amount of out-of-plumb is shown below:

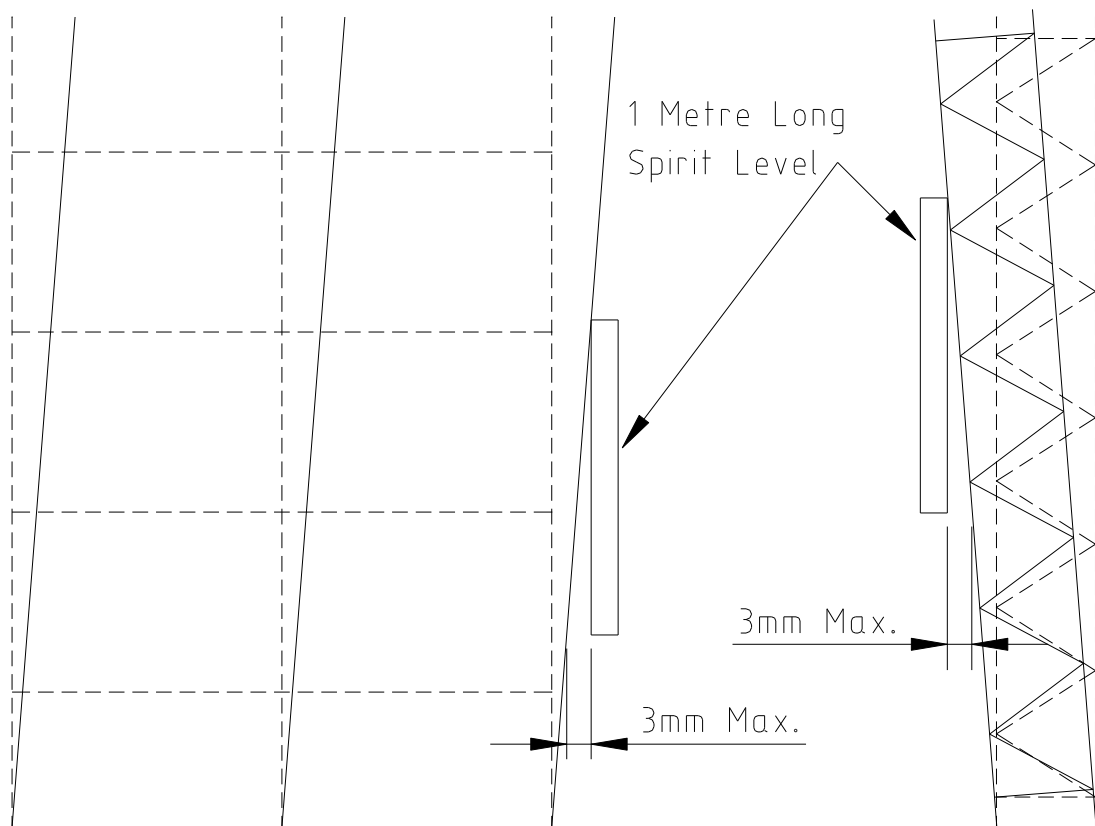

ALONG THE AISLE

ACROSS AISLE

## RISK ASSESSMENT

### GREEN RISK:

#### Damage requiring surveillance

**For damage to frames in which the limits illustrated are not exceeded.**

This would indicate racks where some damage was present but was considered non-critical. Such damaged components should be recorded as suitable for further service until the next management inspection, but clearly identified for further re-examination at future inspections.

### AMBER RISK:

#### Hazardous damage requiring action as soon as possible

**For damage to frames in which the limits illustrated are exceeded by up to a factor of two.**

This would identify an area where the damage was sufficiently severe to warrant remedial work but not so severe as to warrant the immediate off-loading of the rack. Once the rack is unloaded however, it should not be re-loaded until repairs have been carried out. In the event that the storage position remains full for several days after the initial identification of the problem, the rack should be off-loaded for repair without further delay.

The USER company must have a method of isolating such racks to ensure that they do not come back into use until the necessary repairs have been carried out and the equipment certified as safe. For example, use could be made of dated adhesive labels, which indicate racks that are not to be re-loaded until rectified. In practice any racking with **AMBER RISK** category damage should be re-designated **RED RISK** damage if remedial work has not been carried out within four weeks of the original designation.

### RED RISK:

#### Very serious damage requiring immediate action

**For damage to frames in which the limits illustrated exceed a factor greater than two.**

These are situations where a critical level of damage is identified, which warrants an area of racking being immediately off-loaded and isolated from future use until repair work is carried out. Such repair work would involve replacement of the damaged item.

USER companies must have a method of isolating areas to ensure that they do not come back into use prior to the repair work being carried out. For example, a particular bay could be off-loaded in the presence of the inspector and roped off to prevent further use.

### DAMAGE ACTION PROCEDURE FLOWCHART

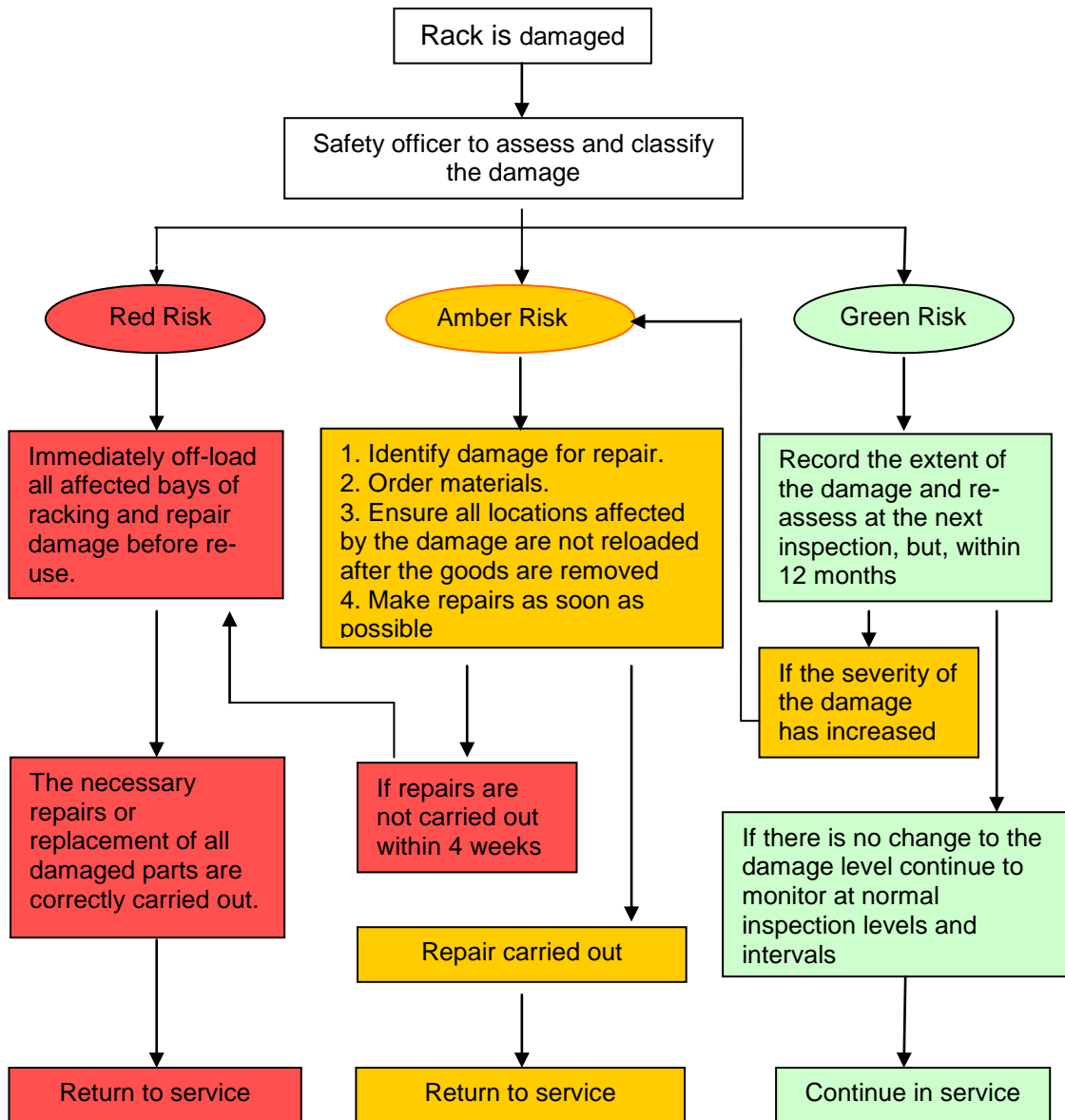



## TYPICAL CAUSES OF DAMAGE

The following are some typical contributing factors as to why damage can occur.

Handling equipment:	Poor or ill maintained equipment or a change in the type and size of handling equipment.
The pallet:	Change in the type or size of pallet used, damaged pallets or load overhang affecting operational clearances.
Truck drivers:	Contract or agency drivers, inexperienced or ill-trained, not familiar with the correct operating procedures, working to high throughput quotas.
Poor housekeeping:	Damaged pallets, unstable loads, obstructions within the aisle.

## PRECAUTIONS AGAINST DAMAGE

The following are all factors that can contribute to minimising the risk of potential damage to the racking system.

Installation layout design:	The provision of adequate operating aisle and transfer aisle widths. Sufficient operating clearances around the stored pallet.
Good management:	Operational procedures, material flow around the warehouse, avoidance of traffic bottlenecks, reporting procedures, training of warehouse staff.
Good housekeeping:	Inspection of and rejection of unsuitable pallets, clearly defined aisles and stacking areas, maintenance of fork lift trucks, warehouse floor etc. and the provision of adequate lighting. Loads are correctly stacked and stable on the pallets.
Good FLT driver training:	Instruction on the correct use of the racking, safety aspects, controlled use of speed within the racking area.
Good aisle markings:	Well defined aisles and transfer aisles, traffic routes, and stacking areas. Floor pallets are not to protrude into the operating aisle.
Provision of guide rails:	This may be a consideration depending on the type of racking system.
Provision of rack protection:	Guards for individual uprights or for the whole frame. Protection helps reduce the effects of accidental damage. They are intended as sacrificial protection that needs to be replaced once damaged and ineffective.